

---

# Empirical Methods in Natural Language Processing

## Lecture 18

### Machine translation (V): Syntax-Based Models

Philipp Koehn

6 March 2008



# Syntax-based SMT

- Why Syntax?
- Yamada and Knight: *translating into trees*
- Wu: *tree-based transfer*
- Chiang: *hierarchical transfer*
- Collins, Kucerova, and Koehn: *clause structure*
- Other approaches

# The Challenge of Syntax

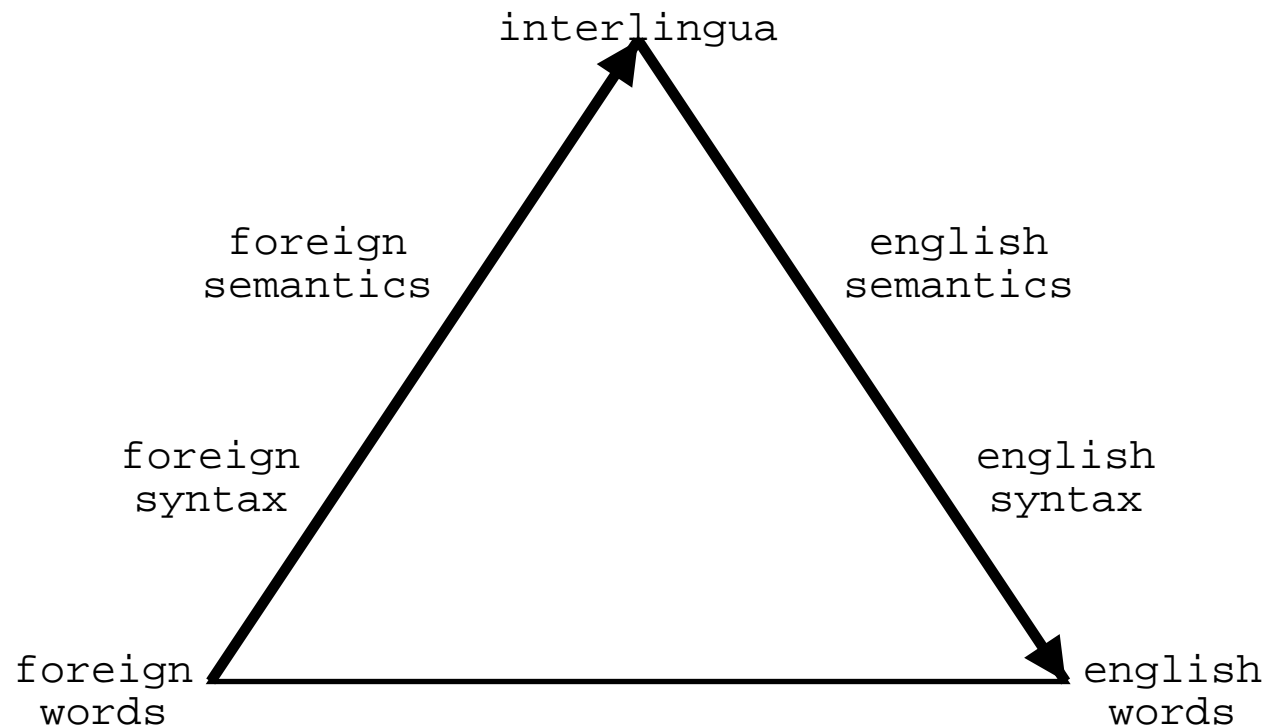

- The classical machine translation *pyramid*

## Advantages of Syntax-Based Translation

- *Reordering* for syntactic reasons
  - e.g., move German object to end of sentence
- Better explanation for *function words*
  - e.g., prepositions, determiners
- Conditioning to *syntactically related words*
  - translation of verb may depend on subject or object
- Use of *syntactic language models*
  - ensuring grammatical output

# Syntactic Language Model

- *Good syntax tree* → good English
- Allows for *long distance constraints*

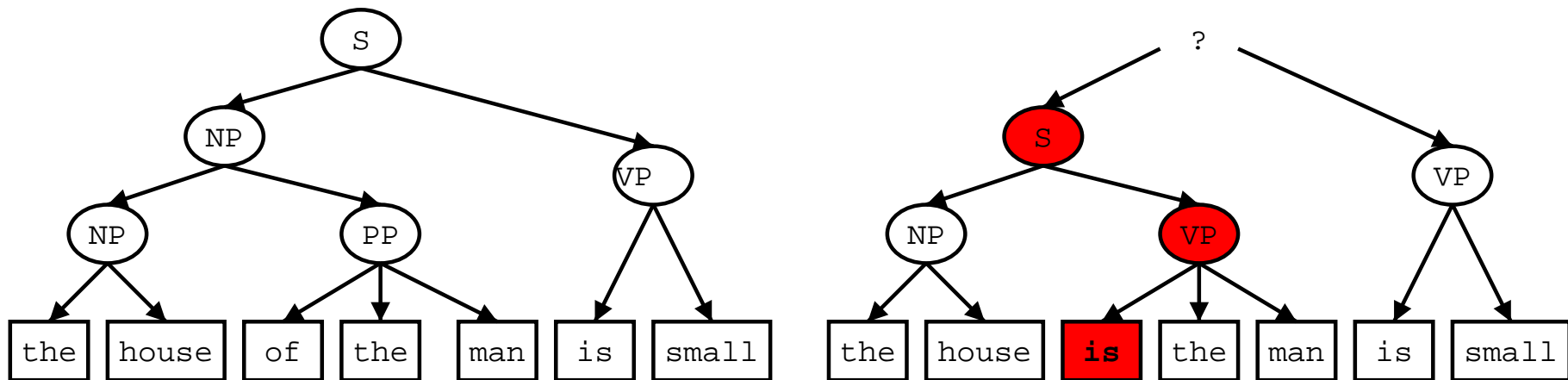

- Left translation preferred by syntactic LM

# String to Tree Translation

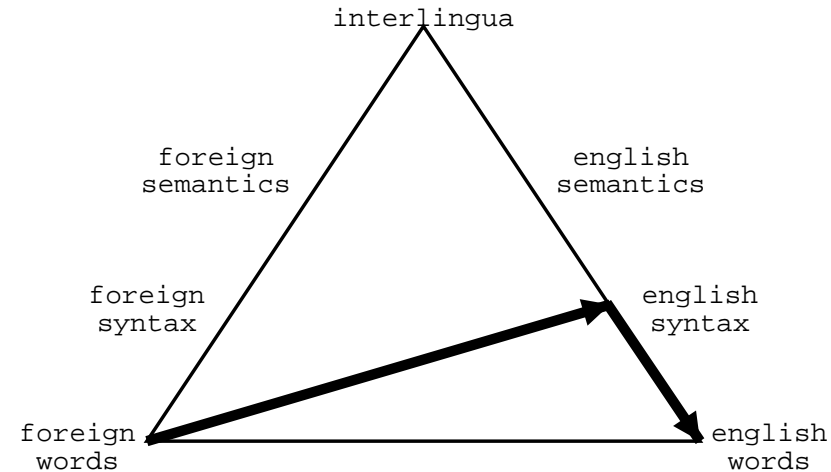

- Use of English *syntax trees* [Yamada and Knight, 2001]
  - exploit *rich resources* on the English side
  - obtained with statistical parser [Collins, 1997]
  - *flattened tree* to allow more reorderings
  - works well with syntactic language model

# Yamada and Knight [2001]

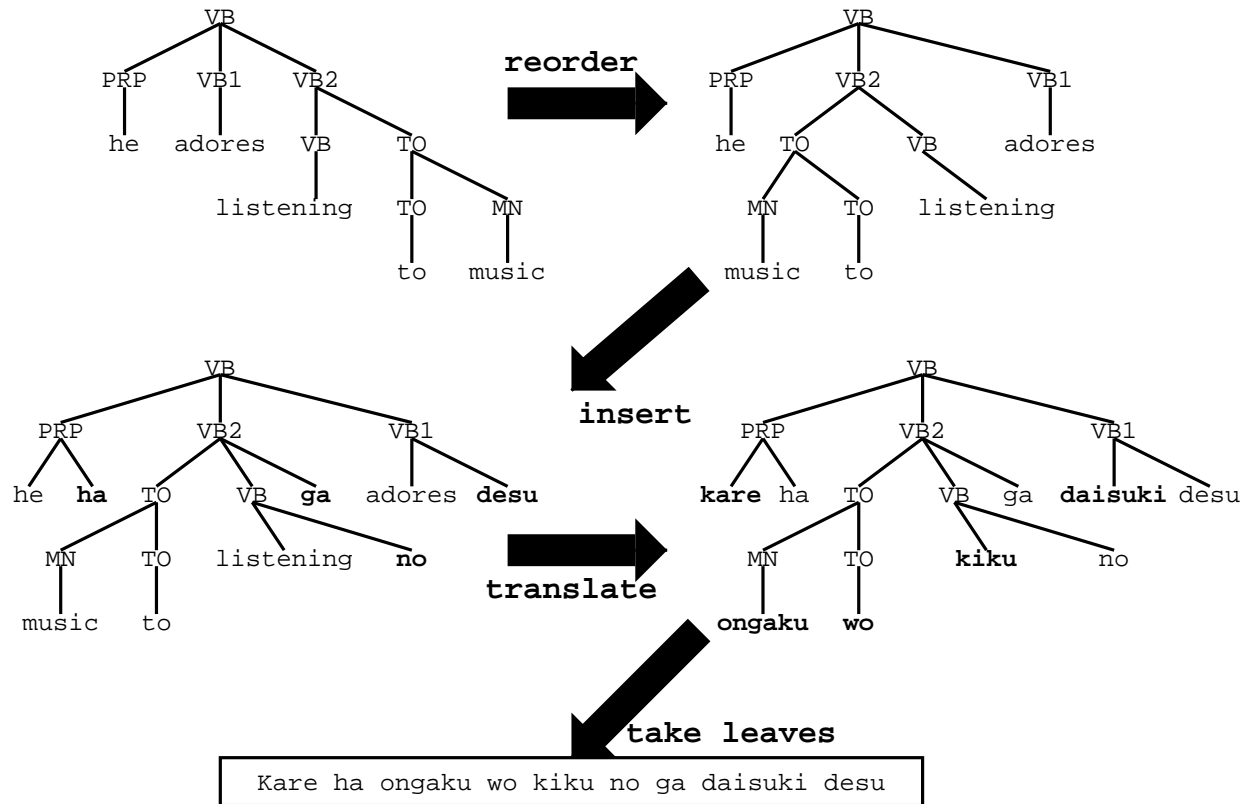

[from Yamada and Knight, 2001]

## Reordering Table

Original Order	Reordering	p(reorder original)
PRP VB1 VB2	PRP VB1 VB2	0.074
<b>PRP VB1 VB2</b>	<b>PRP VB2 VB1</b>	<b>0.723</b>
PRP VB1 VB2	VB1 PRP VB2	0.061
PRP VB1 VB2	VB1 VB2 PRP	0.037
PRP VB1 VB2	VB2 PRP VB1	0.083
PRP VB1 VB2	VB2 VB1 PRP	0.021
VB TO	VB TO	0.107
<b>VB TO</b>	<b>TO VB</b>	<b>0.893</b>
TO NN	TO NN	0.251
<b>TO NN</b>	<b>NN TO</b>	<b>0.749</b>



# Decoding as Parsing

- Chart Parsing

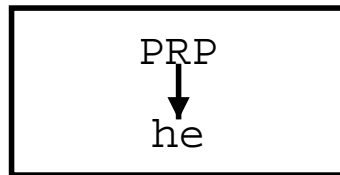

kare ha ongaku wo kiku no ga daisuki desu

- Pick Japanese *words*
- Translate into *tree stumps*

# Decoding as Parsing

- Chart Parsing

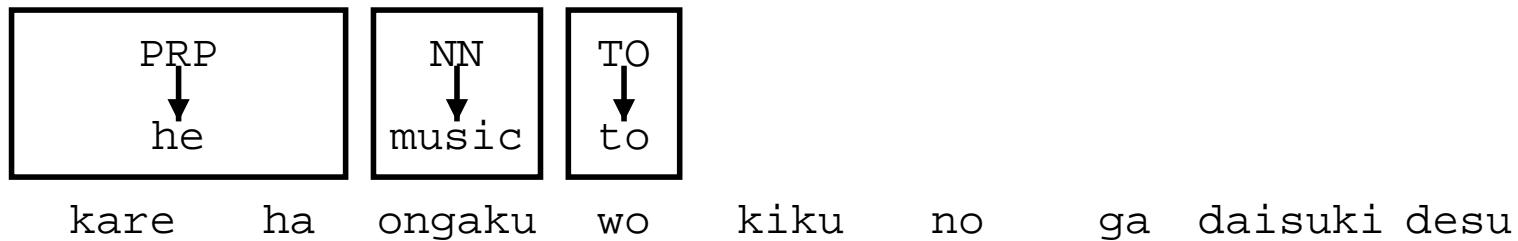

- Pick Japanese words
- Translate into tree stumps

## Decoding as Parsing

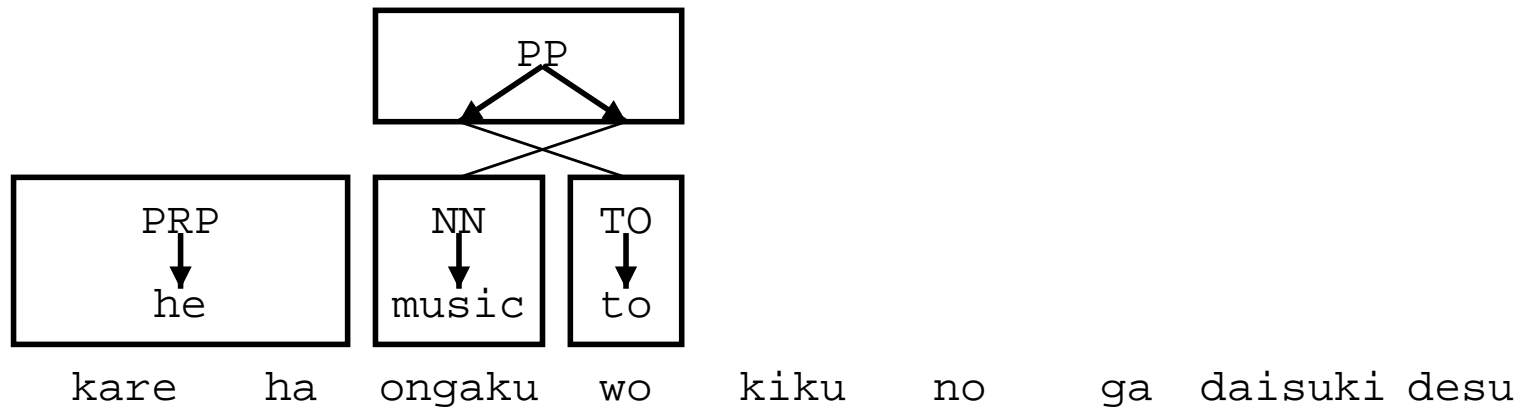

- Adding some *more entries*...

## Decoding as Parsing

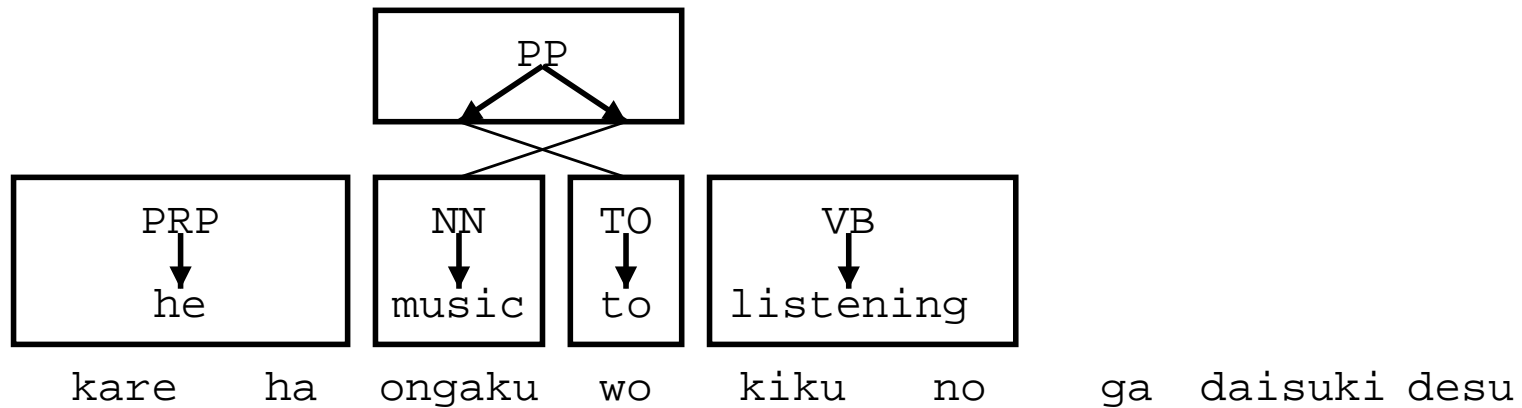

- *Combine entries*

# Decoding as Parsing

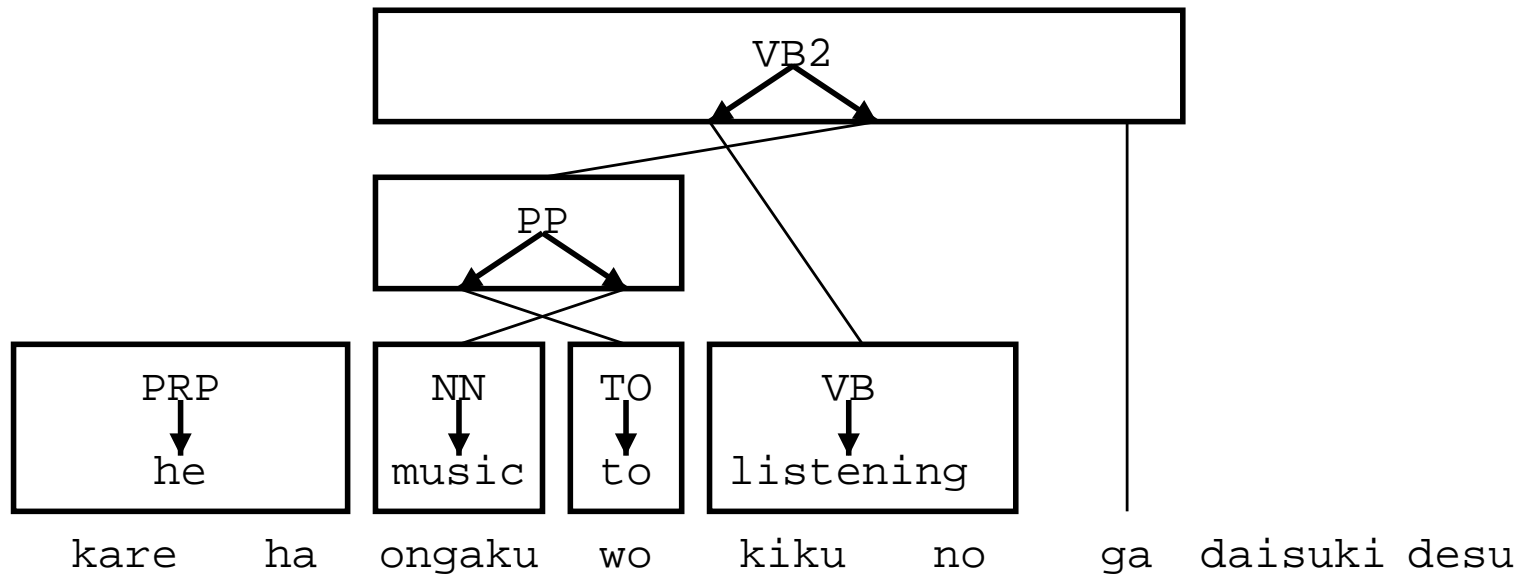

# Decoding as Parsing

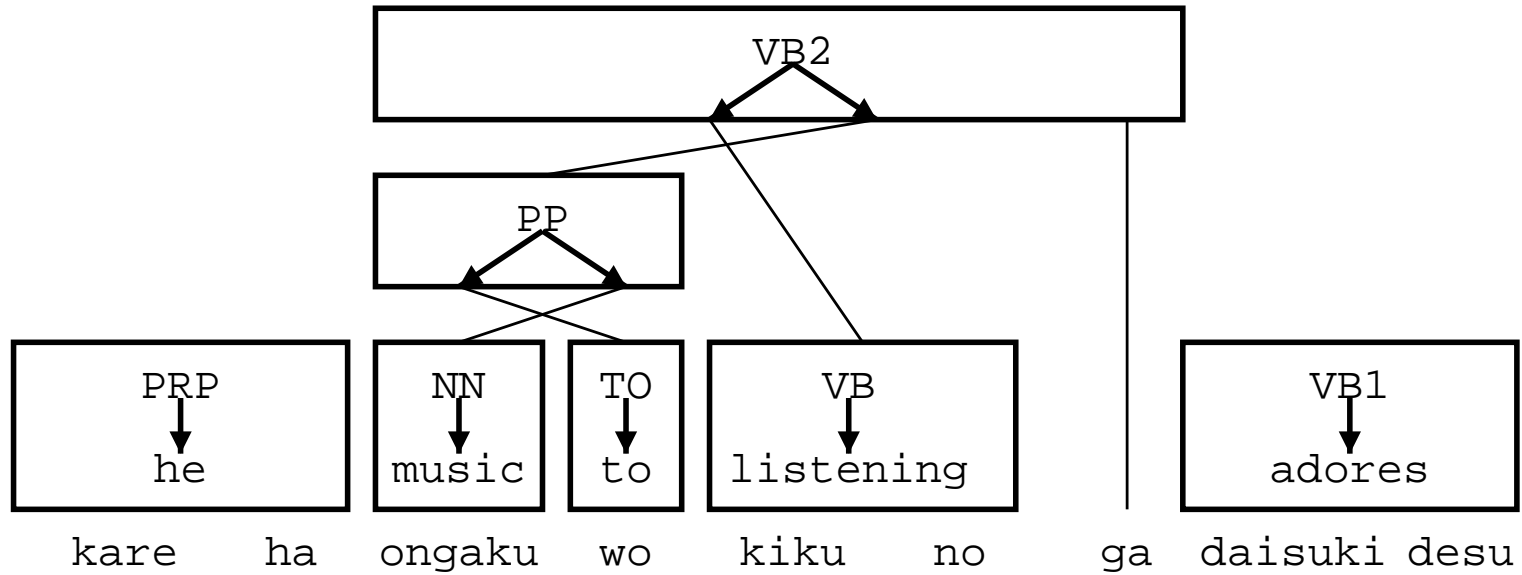

# Decoding as Parsing

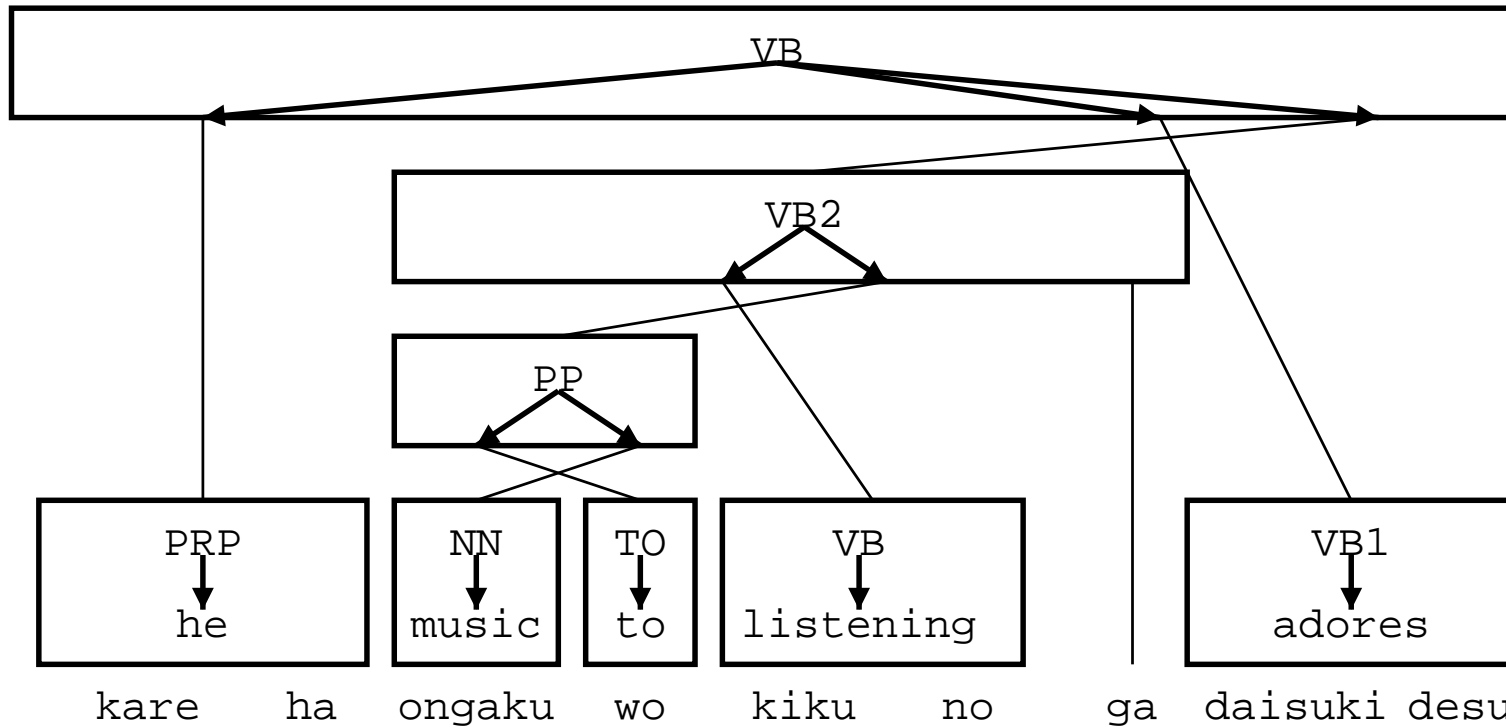

- *Finished* when all foreign words covered

## Yamada and Knight: Training

- *Parsing* of the English side
  - using Collins statistical parser
- *EM training*
  - translation model is used to map training sentence pairs
  - EM training finds low-perplexity model
  - *unity of training and decoding* as in IBM models



## Is the Model Realistic?

- Do English trees *match* foreign strings?
- Crossings between French-English [Fox, 2002]
  - 0.29-6.27 per sentence, depending on how it is measured
- Can be reduced by
  - *flattening tree*, as done by [Yamada and Knight, 2001]
  - detecting *phrasal* translation
  - *special treatment* for small number of constructions
- Most coherence between **dependency structures**

# Inversion Transduction Grammars

- Generation of *both* English and foreign trees [Wu, 1997]
- Rules (binary and unary)
  - $A \rightarrow A_1 A_2 \parallel A_1 A_2$
  - $A \rightarrow A_1 A_2 \parallel A_2 A_1$
  - $A \rightarrow e \parallel f$
  - $A \rightarrow e \parallel *$
  - $A \rightarrow * \parallel f$

⇒ *Common binary tree* required

- limits the complexity of reorderings

# Syntax Trees

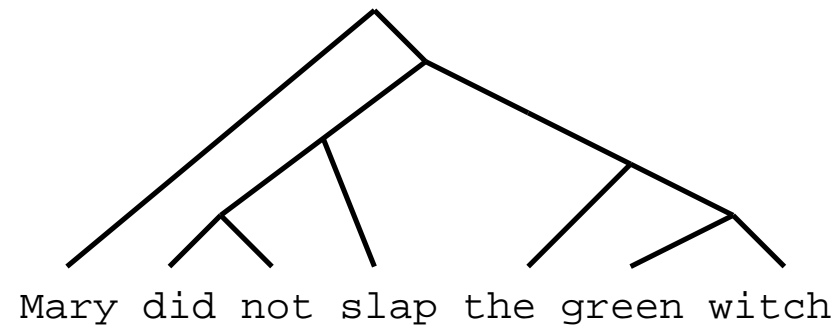

- English binary tree

# Syntax Trees



- Spanish binary tree

# Syntax Trees

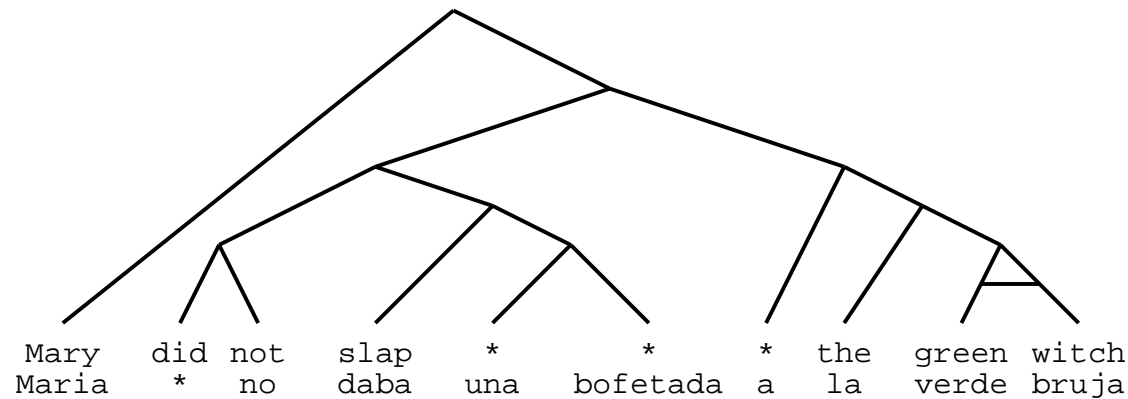

- *Combined tree* with reordering of Spanish

# Inversion Transduction Grammars

- Decoding by parsing (as before)
- Variations
  - may use *real syntax* on either side or both
  - may use *multi-word* units at leaf nodes

## Chiang: Hierarchical Phrase Model

- **Chiang** [ACL, 2005] (best paper award!)
  - context free bi-grammar
  - *one non-terminal* symbol
  - right hand side of rule may include non-terminals and terminals
- *Competitive* with phrase-based models in 2005 DARPA/NIST evaluation

## Types of Rules

- *Word* translation
  - $X \rightarrow \textit{maison} \parallel \textit{house}$
- *Phrasal* translation
  - $X \rightarrow \textit{daba una bofetada} \mid \textit{slap}$
- *Mixed* non-terminal / terminal
  - $X \rightarrow X \textit{bleue} \parallel \textit{blue} X$
  - $X \rightarrow \textit{ne} X \textit{pas} \parallel \textit{not} X$
  - $X \rightarrow X1 X2 \parallel X2 \textit{of} X1$
- Technical rules
  - $S \rightarrow S X \parallel S X$
  - $S \rightarrow X \parallel X$



# Learning Hierarchical Rules

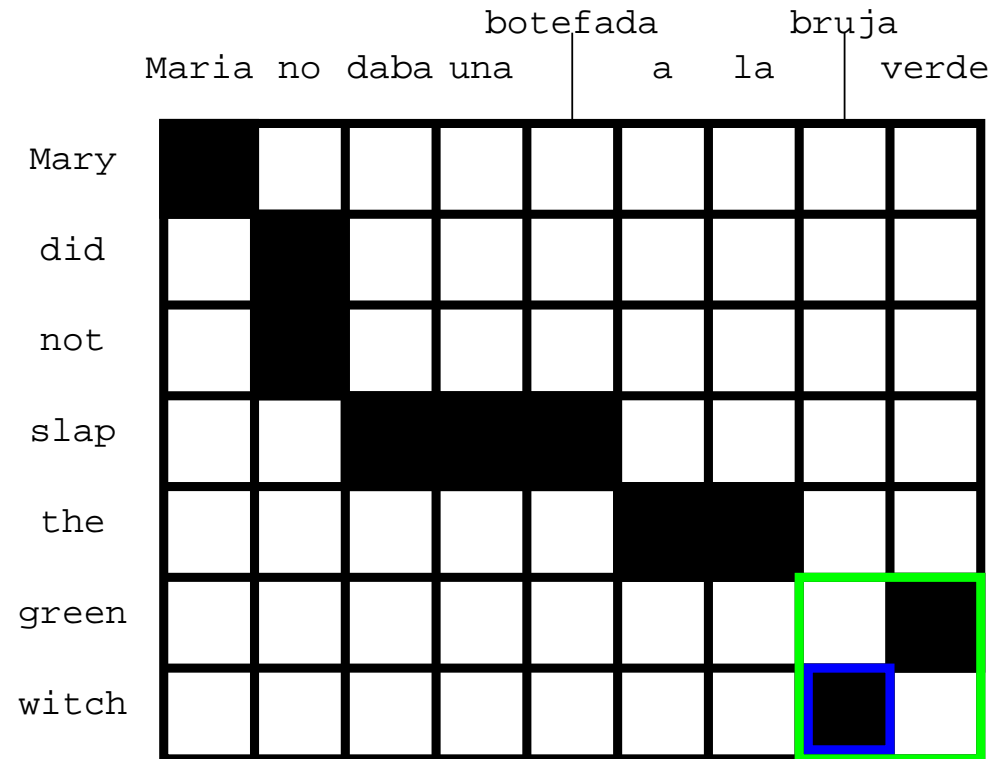

X → X verde || green X

# Learning Hierarchical Rules

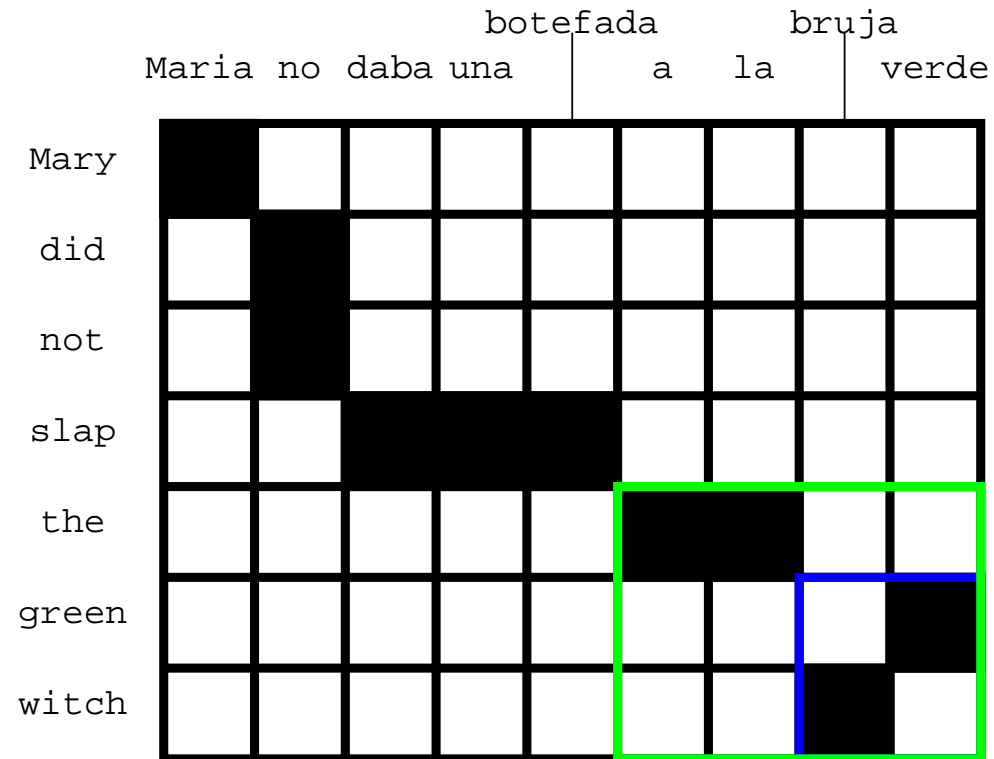

$X \rightarrow a \text{ la } X \parallel \text{the } X$

## Details of Chiang's Model

- Too many rules
  - *filtering* of rules necessary
- *Efficient* parse decoding possible
  - hypothesis stack for each span of foreign words
  - only *one non-terminal* → hypotheses comparable
  - *length limit* for spans that do not start at beginning

# Clause Level Restructuring [Collins et al.]

- Why **clause structure**?
  - languages *differ vastly* in their clause structure  
(English: SVO, Arabic: VSO, German: fairly *free order*;  
a lot details differ: position of adverbs, sub clauses, etc.)
  - large-scale restructuring is a *problem* for phrase models
- **Restructuring**
  - *reordering* of constituents (main focus)
  - add/drop/change of *function words*
- Details see [Collins, Kucerova and Koehn, ACL 2005]



# Reordering When Translating

S	PPER-SB	Ich		I
	VAFIN-HD	werde		will
	PPER-DA	Ihnen		you
	NP-OA	ART-OA	die	the
		ADJ-NK	entsprechenden	corresponding
		NN-NK	Anmerkungen	comments
	VVFIN	aushaendigen		pass on
\$,				
S-MO	KOUS-CP	damit		' so that
	PPER-SB	Sie		you
	PDS-OA	das		that
	ADJD-MO	eventuell		perhaps
	PP-MO	APRD-MO	bei	in
		ART-DA	der	the
		NN-NK	Abstimmung	vote
	VVINF	uebernehmen		include
	VMFIN	koennen		can
\$. .				.

- *Reordering* when translating into English
  - tree is *flattened*
  - clause level constituents line up

## Clause Level Reordering

S	PPER-SB	Ich	_____	1	I	
	VAFIN-HD	werde	_____	2	will	
	PPER-DA	Ihnen	_____	4	you	
	NP-OA	ART-OA	die		the	
		ADJ-NK	entsprechenden		5	corresponding
		NN-NK	Anmerkungen		comments	
	VVFIN	aushaendigen	_____	3	pass on	
\$,					,	
S-MO	KOUS-CP	damit	_____	1	so that	
	PPER-SB	Sie	_____	2	you	
	PDS-OA	das	_____	6	that	
	ADJD-MO	eventuell	_____	4	perhaps	
	PP-MO	APRD-MO	bei		in	
		ART-DA	der		7	the
		NN-NK	Abstimmung		vote	
	VVINF	uebernehmen	_____	5	include	
	VMFIN	koennen	_____	3	can	
\$. .					.	

- Clause level reordering is a *well defined task*
  - label German constituents with their *English order*
  - done this for 300 sentences, two annotators, high agreement

## Systematic Reordering German → English

- Many types of reorderings are **systematic**

- *move verb group together*
- *subject - verb - object*
- *move negation in front of verb*

⇒ *Write rules by hand*

- apply rules to test and training data
- train standard *phrase-based* SMT system

System	BLEU
baseline system	25.2%
with manual rules	26.8%



## Improved Translations

- we **must also** this criticism **should be taken** seriously .  
→ we **must also take** this criticism seriously .
- i **am with him** that it is necessary , the institutional balance by means of a political revaluation of both the commission and the council **to maintain** .  
→ i **agree with him in this** , that it is necessary **to maintain** the institutional balance by means of a political revaluation of both the commission and the council .
- thirdly , we **believe that** the principle of differentiation of negotiations **note** .  
→ thirdly , we **maintain** the principle of differentiation of negotiations .
- perhaps **it would be** a constructive dialog between the government and opposition parties , social representative a positive impetus in the right direction .  
→ perhaps a constructive dialog between government and opposition parties and social representative **could give** a positive impetus in the right direction .

## Other Syntax-Based Approaches

- ISI: extending work of Yamada/Knight
  - more *complex rules*
  - performance approaching phrase-based
- Prague: Translation via *dependency structures*
  - parallel Czech–English dependency treebank
  - tecto-grammatical translation model [EACL 2003]
- U.Alberta/Microsoft: *treelet translation*
  - translating from English into foreign languages
  - using dependency parser in English
  - project *dependency tree* into foreign language for training
  - map parts of the dependency tree (“treelets”) into foreign languages

## Other Syntax-Based Approaches

- *Reranking* phrase-based SMT output with syntactic features
  - create n-best list with phrase-based system
  - POS tag and parse candidate translations
  - rerank with syntactic features
  - see [Koehn, 2003] and JHU Workshop [Och et al., 2003]
- JHU Summer workshop 2005
  - **Genpar**: tool for syntax-based SMT

## Syntax: Does it help?

- *Getting there*
  - for some languages competitive with best phrase-based systems
- *Some evidence*
  - work on reordering German
  - ISI: better for short sentences Chinese–English
  - automatically trained tree transfer systems promising
- Why not yet?
  - if real syntax, we need *good parsers* — are they good enough?
  - syntactic annotations add a level of *complexity*
  - difficult to handle, slow to train and decode
  - few researchers good at statistical modeling and syntactic theories