



Music Informatics

Alan Smaill

Mar 4th 2014

- ▶ Imitating musical style
- ▶ Cope: grammar + signature patterns

Alan Turing's famous paper from 1950 "Computing Machinery and Intelligence" can be found in many places, eg

<http://www.abelard.org/turpap/turpap.htm>

He proposed to replace the question "Can a machine think?" with one where there is a clear way to decide what the outcome is: Can we distinguish between the behaviour of a human and a machine?

It is proposed that a machine may be deemed intelligent, if it can act in such a manner that a human cannot distinguish the machine from another human merely by asking questions via a mechanical link.

Turing, 1950

David Cope over many years has worked on a general approach to machine imitation of music in particular styles. There is a corresponding question that he has used:

Can people tell if music they hear is by a composer (in the given style) or by machine?

There is literature on the notion of musical intelligence – not only composition in the western tradition, but musical ability in general. See for example

Intelligence in traditional music

Simha Arom

in "What is intelligence?" Jean Khalifa (ed), Cambridge UP.

Cope has written extensively about the area of machine composition and the associated philosophical debates. His web site is a good place to find out the sorts of things he has been involved in:

<http://artsites.ucsc.edu/faculty/cope/>

In particular, books:

- ▶ 1991. Computers and Musical Style. Madison, WI: A-R Editions.
- ▶ 1996. Experiments in Musical Intelligence. Madison, WI: A-R Editions.
- ▶ 2005. Computer Models of Musical Creativity. Cambridge, MA: MIT Press

His approach is a mixture of hand-crafted grammars to capture the **structure** associated with particular style (eg Bach 2 part invention), and machine analysis of local repeated patterns that are used in generating new music.

The mark of the composer (or composers) is in the **local** stylistic markers, not in the structure which is more generic. The patterns here are called **signatures**.

This is yet another version of musical **similarity**, which again involves various decisions as to how this is defined.

The grammar formalism used here is that of ATNs (Augmented Transition Networks), which were developed for natural language analysis.

This is a version of finite-state automaton. A graph shows **states** labelled with grammar categories, and directed **edges** also labelled. There are a number of such graphs, one for each grammar category. Also special states:

- ▶ the start state
- ▶ accepting state(s)

This defines a language by looking at the possible paths from the initial state to an accepting state, where an edge labelled with a category calls this process recursively with the appropriate graph (or takes a symbol from a given class).

Simple example

Which strings made from “e”, “0”, “1” are accepted/generated by this finite state automaton?
(Initial state is q_0 , final states are q_1, q_5 .)

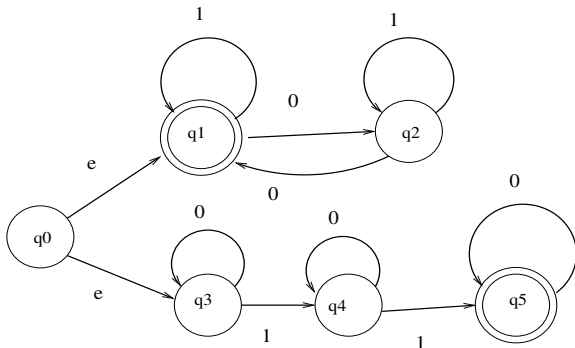

See natural language and musical examples on hand-out. (Here a single graph is used, things can get more complicated.) Examples from “Computers and Musical Style”, pp 62–65.

Although Cope produces these by hand, there are techniques for learning grammars from sufficiently many examples; this is known as “grammar induction”.

*[http://labh-curien.univ-st-etienne.fr/
informatique/gi/](http://labh-curien.univ-st-etienne.fr/informatique/gi/)*

In the case of Bach inventions, where a grammar is available that ensure the right form (2 voices, phrase structure, cadences, etc):

Given two or more pieces in the chosen style:

Find pitch motives

Look for similarities between the motives,
to build dictionary of signatures

Classify the signature according to the grammar

Pick from motives to fit the grammar

A **signature** is a set of consecutive pitch intervals found in more than one work by the same composer; typically:

- ▶ 2–9 notes melodically
- ▶ generally not influenced by rhythm

When looking for similarities, make use of assumptions of WTM eg, transpose into common key. The signature dictionary also records how frequently the signature occurs in the input pieces. There is a detailed account of the program specialised for inventions in “Computers and Musical Style”; it is written in LISP. It fits into the larger-scale composition framework.

Example Signatures

Here are four snippets associated belonging to the same signature
(Computers and Musical Style p 151, from Bach Invention no 15):



Although these share the same rhythm, the signatures are primarily given in terms of sequences of intervals.

As Cope says:

Composing phrases of language or music is quite different from analyzing them. Finding form in works of art, be they stories or compositions, is not difficult. The reverse ... is not at all a simple matter.

In other words, “grammatical” is usually not enough to ensure that the output makes any sense. It is not clear (to me) to what extent Cope’s programs nudge the result in particular directions, or how selective he is in discarding results on the basis of personal taste.

See handout “Computers and Musical Style”, pp 152–157, for the steps involved in the construction of these pieces at that time. Notice that a lot of style-specific information is encoded, along with the structural (via grammar) and stylistic (via signatures) information.

Cope looked for example at combining pieces from different traditions – eg based on Bach first prelude from the 48 preludes and fugues. (See on Cope's EMI page.)

Listen also to the Beethoven example, based on the slow movement from the Moonlight Sonata, where the signatures are gathered from other famous Beethoven sonatas (Appassionata, Pathétique, ...).

Cope took this round AI conferences, asking people whether they can tell the machine composition from the real things. It did well among those without a background in classical music, not so well with those who knew the styles better.

- ▶ Machine stylistic imitation
- ▶ Grammar for structure, patterns for style, . . .