

# Why is Haskell called Haskell?

Philip Wadler

University of Edinburgh

wadler@inf.ed.ac.uk

Lambda



Part 0

Boolean algebra

# George Boole (1815–1864)

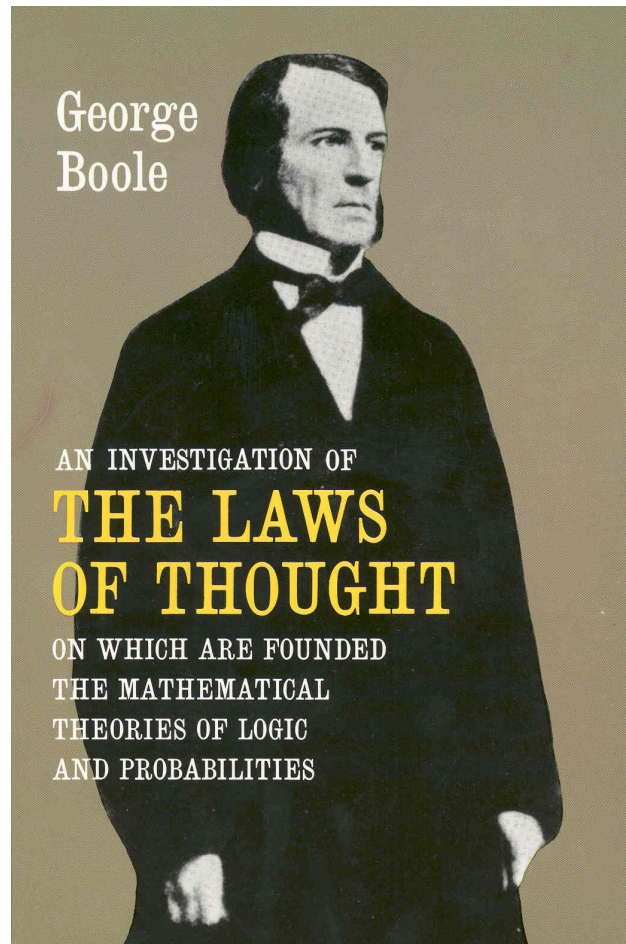

# Boole 1847: Mathematical analysis of logic

The primary canonical forms already determined for the expression of Propositions, are

|                     |                 |        |
|---------------------|-----------------|--------|
| All Xs are Ys,      | $x(1 - y) = 0,$ | ....A. |
| No Xs are Ys,       | $xy = 0,$       | ....E. |
| Some Xs are Ys,     | $v = xy,$       | ....I. |
| Some Xs are not Ys, | $v = x(1 - y)$  | ....O. |

On examining these, we perceive that E and I are symmetrical with respect to  $x$  and  $y$ , so that  $x$  being changed into  $y$ , and  $y$  into  $x$ , the equations remain unchanged. Hence E and I may be interpreted into

No Ys are Xs,  
Some Ys are Xs,

respectively. Thus we have the known rule of the Logicians, that particular affirmative and universal negative Propositions admit of simple conversion. |

## Boole 1854: Laws of Thought

### PROPOSITION IV.

*That axiom of metaphysicians which is termed the principle of contradiction, and which affirms that it is impossible for any being to possess a quality, and at the same time not to possess it, is a consequence of the fundamental law of thought, whose expression is  $x^2 = x$ .*

Let us write this equation in the form

$$x - x^2 = 0,$$

whence we have

$$x(1 - x) = 0; \tag{1}$$

both these transformations being justified by the axiomatic laws of combination and transposition (II. 13). Let us, for simplicity

Part 1

Frege's *Begriffsschrift*

# Gotlob Frege (1848–1925)

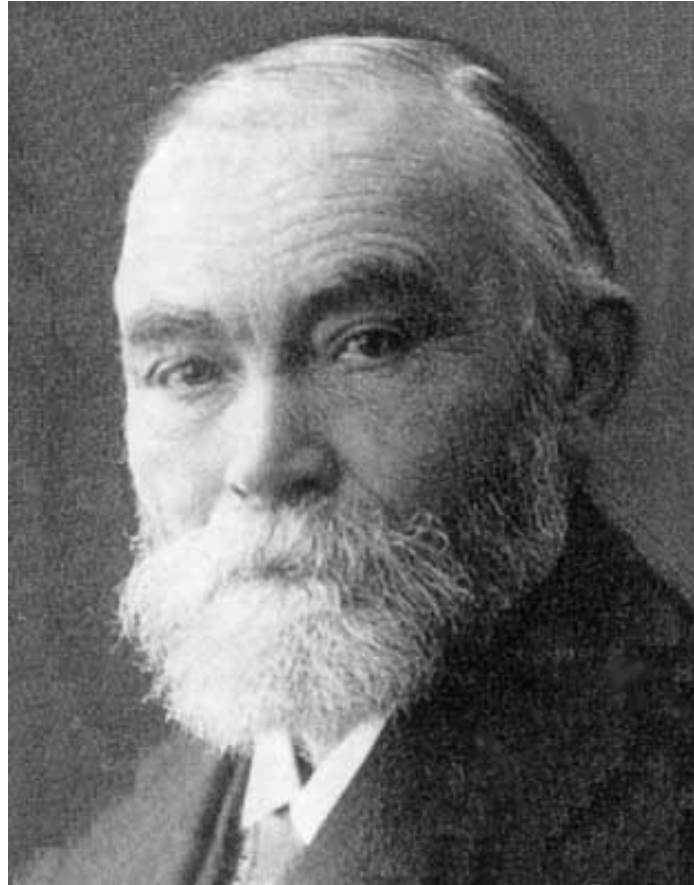



## Frege 1879 — *modus ponens*

We could write this inference perhaps as follows :

$$\begin{array}{l} \vdash A \\ \quad \vdash B \end{array}$$
$$\vdash B$$

---

$$\vdash A.$$

This would become awkward if long expressions were to take the places of  $A$  and  $B$ , since each of them would have to be written twice. That is why I use the following

# Frege 1879 — *modus ponens*

We could write this inference perhaps as follows :

$$\begin{array}{l} \vdash \quad A \\ \quad \vdash \quad B \end{array}$$
$$\vdash \quad B$$

---

$$\vdash \quad A.$$

This would become awkward if long expressions were to take the places of  $A$  and  $B$ , since each of them would have to be written twice. That is why I use the following

$$\frac{B \supset A \quad B}{A}$$

# Frege 1879 — quantification

*It is clear also that from*

$$\vdash \frac{\quad}{A} \Phi(a)$$

*we can derive*

$$\vdash \frac{\quad}{A} \Phi(a)$$

*if  $A$  is an expression in which  $a$  does not occur and if  $a$  stands only in the argument places of  $\Phi(a)$ .<sup>14</sup> If  $\frac{\quad}{A} \Phi(a)$  is denied, we must be able to specify a meaning for  $a$  such that  $\Phi(a)$  will be denied. If, therefore,  $\frac{\quad}{A} \Phi(a)$  were to be denied and*

# Frege 1879 — quantification

*It is clear also that from*

$$\vdash \frac{}{A \supset \Phi(a)}$$

*we can derive*

$$\vdash \frac{}{A \supset \forall a. \Phi(a)}$$

*if  $A$  is an expression in which  $a$  does not occur and if  $a$  stands only in the argument places of  $\Phi(a)$ .<sup>14</sup> If  $\neg \forall a. \Phi(a)$  is denied, we must be able to specify a meaning for  $a$  such that  $\Phi(a)$  will be denied. If, therefore,  $\neg \forall a. \Phi(a)$  were to be denied and*

$$\frac{A \supset \Phi(a)}{A \supset \forall a. \Phi(a)}$$

# Frege 1879

52

FREGE

We see how this judgment replaces one mode of inference, namely, Felapton or Fesapo, between which we do not distinguish here since no subject has been singled out.

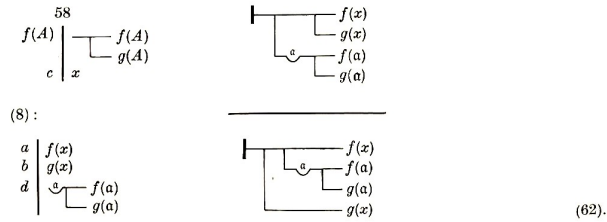
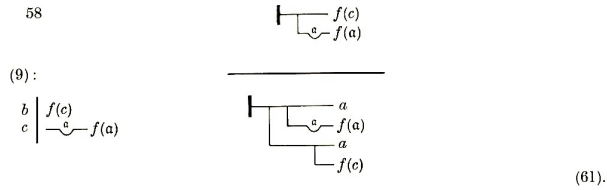
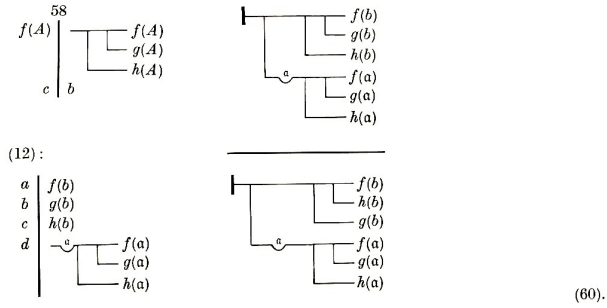

This judgment replaces the mode of inference Barbara when the minor premiss,  $g(x)$ , has a particular content.

BEGRIFFSSCHRIFT

53

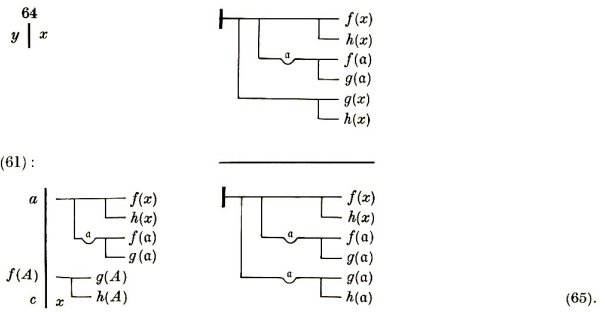
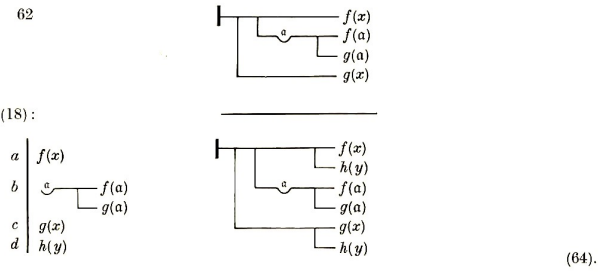
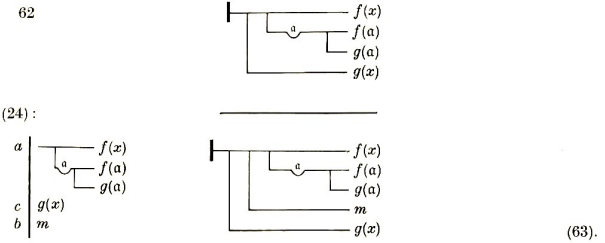

# Frege in modern notation

$$\frac{B \supset A \quad B}{A}$$

$$A \supset (B \supset A)$$

$$(C \supset (B \supset A)) \supset ((C \supset B) \supset (C \supset A))$$

$$(C \supset (B \supset A)) \supset (B \supset (C \supset A))$$

## Part 2

# Gentzen's Natural Deduction

# Gerhard Gentzen (1909–1945)





# Gentzen 1934: Natural Deduction

|   |  |  |   |
|---|--|--|---|
| $\&-I$ $\frac{\mathcal{A} \quad \mathcal{B}}{\mathcal{A} \& \mathcal{B}}$                                       | $\&-E$ $\frac{\mathcal{A} \& \mathcal{B}}{\mathcal{A}} \quad \frac{\mathcal{A} \& \mathcal{B}}{\mathcal{B}}$ | $\vee-I$ $\frac{\mathcal{A}}{\mathcal{A} \vee \mathcal{B}} \quad \frac{\mathcal{B}}{\mathcal{A} \vee \mathcal{B}}$ | $\vee-E$ $\frac{\mathcal{A} \vee \mathcal{B} \quad \begin{array}{c} [\mathcal{A}] \\ \mathcal{C} \end{array} \quad \begin{array}{c} [\mathcal{B}] \\ \mathcal{C} \end{array}}{\mathcal{C}}$ |
| $\forall-I$ $\frac{\mathcal{F}a}{\forall x \mathcal{F}x}$   | $\forall-E$ $\frac{\forall x \mathcal{F}x}{\mathcal{F}a}$  | $\exists-I$ $\frac{\mathcal{F}a}{\exists x \mathcal{F}x}$  | $\exists-E$ $\frac{\exists x \mathcal{F}x \quad \begin{array}{c} [\mathcal{F}a] \\ \mathcal{C} \end{array}}{\mathcal{C}}$   |
| $\supset-I$ $\frac{\begin{array}{c} [\mathcal{A}] \\ \mathcal{B} \end{array}}{\mathcal{A} \supset \mathcal{B}}$ | $\supset-E$ $\frac{\mathcal{A} \quad \mathcal{A} \supset \mathcal{B}}{\mathcal{B}}$                          | $\neg-I$ $\frac{\begin{array}{c} [\mathcal{A}] \\ \wedge \end{array}}{\neg \mathcal{A}}$                           | $\neg-E$ $\frac{\mathcal{A} \quad \neg \mathcal{A}}{\wedge} \quad \frac{\wedge}{\mathcal{D}}$   |

# Gentzen 1934: Natural Deduction

$$\frac{\begin{array}{c} [A]^x \\ \vdots \\ B \end{array}}{A \supset B} \supset\text{-I}^x \qquad \frac{A \supset B \quad A}{B} \supset\text{-E}$$

$$\frac{A \quad B}{A \& B} \&\text{-I} \qquad \frac{A \& B}{A} \&\text{-E}_0 \qquad \frac{A \& B}{B} \&\text{-E}_1$$

# A proof

$$\frac{\frac{[B \& A]^z}{A} \&-E_1 \quad \frac{[B \& A]^z}{B} \&-E_0}{A \& B} \&-I$$
$$\frac{A \& B}{(B \& A) \supset (A \& B)} \supset-I^z$$

# Simplifying proofs

$$\frac{\frac{\begin{array}{c} [A]^x \\ \vdots \\ B \end{array}}{A \supset B} \supset\text{-I}^x \quad \begin{array}{c} \vdots \\ A \end{array}}{B} \supset\text{-E} \quad \Rightarrow \quad \begin{array}{c} \vdots \\ A \\ \vdots \\ B \end{array}$$

$$\frac{\frac{\begin{array}{c} \vdots \\ A \end{array} \quad \begin{array}{c} \vdots \\ B \end{array}}{A \& B} \&\text{-I} \quad \begin{array}{c} \vdots \\ A \end{array}}{A} \&\text{-E}_0 \quad \Rightarrow \quad \begin{array}{c} \vdots \\ A \end{array}$$

## Simplifying a proof

$$\frac{\frac{\frac{[B \& A]^z}{A} \&-E_1 \quad \frac{[B \& A]^z}{B} \&-E_0}{A \& B} \&-I \quad \frac{[B]^y \quad [A]^x}{B \& A} \&-I}{(B \& A) \supset (A \& B) \supset-I^z \quad B \& A \supset-E} \supset-E$$
$$\frac{}{A \& B}$$

## Simplifying a proof

$$\begin{array}{c}
 \frac{[B \& A]^z}{A} \&-E_1 \quad \frac{[B \& A]^z}{B} \&-E_0 \\
 \hline
 A \& B \quad \&-I \\
 \hline
 (B \& A) \supset (A \& B) \quad \supset-I^z \\
 \hline
 \frac{A \& B \quad \frac{[B]^y \quad [A]^x}{B \& A} \&-I}{A \& B} \supset-E
 \end{array}$$

$\Downarrow$

$$\begin{array}{c}
 \frac{[B]^y \quad [A]^x}{B \& A} \&-I \quad \frac{[B]^y \quad [A]^x}{B \& A} \&-I \\
 \hline
 \frac{B \& A}{A} \&-E_1 \quad \frac{B \& A}{B} \&-E_0 \\
 \hline
 A \& B \quad \&-I
 \end{array}$$

# Simplifying a proof

$$\begin{array}{c}
 \frac{[B \& A]^z}{A} \&-E_1 \quad \frac{[B \& A]^z}{B} \&-E_0 \\
 \hline
 A \& B \quad \&-I \\
 \hline
 (B \& A) \supset (A \& B) \supset-I^z \\
 \hline
 \frac{(B \& A) \supset (A \& B) \quad \frac{[B]^y \quad [A]^x}{B \& A} \&-I}{A \& B} \supset-E \\
 \\
 \Downarrow \\
 \frac{\frac{[B]^y \quad [A]^x}{B \& A} \&-I \quad \frac{[B]^y \quad [A]^x}{B \& A} \&-I}{\frac{B \& A}{A} \&-E_1 \quad \frac{B \& A}{B} \&-E_0} \&-I \\
 \hline
 A \& B \\
 \\
 \Downarrow \\
 \frac{[A]^x \quad [B]^y}{A \& B} \&-I
 \end{array}$$

## Part 3

# Church's Lambda Calculus



# Alonzo Church (1903–1995)



# Church 1932: Lambda Calculus

An occurrence of a variable  $\mathbf{x}$  in a given formula is called an occurrence of  $\mathbf{x}$  as a *bound variable* in the given formula if it is an occurrence of  $\mathbf{x}$  in a part of the formula of the form  $\lambda \mathbf{x}[\mathbf{M}]$ ; that is, if there is a formula  $\mathbf{M}$  such that  $\lambda \mathbf{x}[\mathbf{M}]$  occurs in the given formula and the occurrence of  $\mathbf{x}$  in question is an occurrence in  $\lambda \mathbf{x}[\mathbf{M}]$ . All other occurrences of a variable in a formula are called occurrences as a *free variable*.

A formula is said to be *well-formed* if it is a variable, or if it is one

# Reduction rules

$$(\lambda x. u) t \Rightarrow u[t/x]$$

$$\text{fst } (t, u) \Rightarrow t$$

$$\text{snd } (t, u) \Rightarrow u$$

# Simplifying a term

$$(\lambda z. (\text{snd } z, \text{fst } z)) (y, x)$$

# Simplifying a term

$$(\lambda z. (\text{snd } z, \text{fst } z)) (y, x)$$
$$\Downarrow$$
$$(\text{snd } (y, x), \text{fst } (y, x))$$

# Simplifying a term

$$(\lambda z. (\text{snd } z, \text{fst } z)) (y, x)$$
$$\Downarrow$$
$$(\text{snd } (y, x), \text{fst } (y, x))$$
$$\Downarrow$$
$$(x, y)$$

# Church 1940: Typed Lambda Calculus

$$\frac{\begin{array}{c} [x : A]^x \\ \vdots \\ u : B \end{array}}{\lambda x. u : A \supset B} \supset\text{-I}^x \qquad \frac{s : A \supset B \quad t : A}{st : B} \supset\text{-E}$$

$$\frac{t : A \quad u : B}{(t, u) : A \& B} \&\text{-I}$$

$$\frac{s : A \& B}{\text{fst } s : A} \&\text{-E}_0$$

$$\frac{s : A \& B}{\text{snd } s : B} \&\text{-E}_1$$

# A program

$$\frac{\frac{[z : B \& A]^z}{\text{snd } z : A} \&-E_1 \quad \frac{[z : B \& A]^z}{\text{fst } z : B} \&-E_0}{\frac{}{(\text{snd } z, \text{fst } z) : A \& B} \&-I} \supset-I^z$$
$$\lambda z. (\text{snd } z, \text{fst } z) : (B \& A) \supset (A \& B)$$



# Simplifying programs

$$\frac{\frac{\begin{array}{c} [x : A]^x \\ \vdots \\ u : B \end{array}}{\lambda x. u : A \supset B} \supset\text{-I}^x \quad \begin{array}{c} \vdots \\ t : A \end{array}}{\frac{\lambda x. u : A \supset B \quad t : A}{(\lambda x. u) t : B} \supset\text{-E}} \Rightarrow \begin{array}{c} \vdots \\ t : A \\ \vdots \\ u[t/x] : B \end{array}$$

$$\frac{\frac{\begin{array}{c} \vdots \\ t : A \end{array} \quad \begin{array}{c} \vdots \\ u : B \end{array}}{(t, u) : A \& B} \&\text{-I}}{\frac{(t, u) : A \& B}{\text{fst } (t, u) : A} \&\text{-E}_0} \Rightarrow \begin{array}{c} \vdots \\ t : A \end{array}$$

# Simplifying a program

$$\frac{\frac{\frac{[z : B \& A]^z}{\text{snd } z : A} \&-E_1 \quad \frac{[z : B \& A]^z}{\text{fst } z : B} \&-E_0}{(\text{snd } z, \text{fst } z) : A \& B} \&-I}{\lambda z. (\text{snd } z, \text{fst } z) : (B \& A) \supset (A \& B)} \supset-I^z \quad \frac{\frac{[y : B]^y \quad [x : A]^x}{(y, x) : B \& A} \&-I}{(\lambda z. (\text{snd } z, \text{fst } z)) (y, x) : A \& B} \supset-E$$

# Simplifying a program

$$\frac{\frac{[z : B \& A]^z}{\text{snd } z : A} \&-E_1 \quad \frac{[z : B \& A]^z}{\text{fst } z : B} \&-E_0}{(\text{snd } z, \text{fst } z) : A \& B} \&-I \quad \frac{[y : B]^y \quad [x : A]^x}{(y, x) : B \& A} \&-I}{\lambda z. (\text{snd } z, \text{fst } z) : (B \& A) \supset (A \& B) \quad (y, x) : B \& A} \supset-I^z \quad \supset-E$$

$$(\lambda z. (\text{snd } z, \text{fst } z)) (y, x) : A \& B$$

↓

$$\frac{\frac{[y : B]^y \quad [x : A]^x}{(y, x) : B \& A} \&-I \quad \frac{[y : B]^y \quad [x : A]^x}{(y, x) : B \& A} \&-I}{\text{snd } (y, x) : A \quad \text{fst } (y, x) : B} \&-E_1 \quad \&-E_0}{(\text{snd } (y, x), \text{fst } (y, x)) : A \& B} \&-I$$

# Simplifying a program

$$\frac{\frac{\frac{[z : B \& A]^z}{\text{snd } z : A} \&-E_1 \quad \frac{[z : B \& A]^z}{\text{fst } z : B} \&-E_0}{(\text{snd } z, \text{fst } z) : A \& B} \&-I}{\lambda z. (\text{snd } z, \text{fst } z) : (B \& A) \supset (A \& B)} \supset-I^z \quad \frac{\frac{[y : B]^y \quad [x : A]^x}{(y, x) : B \& A} \&-I}{(\lambda z. (\text{snd } z, \text{fst } z)) (y, x) : A \& B} \supset-E$$

↓

$$\frac{\frac{\frac{[y : B]^y \quad [x : A]^x}{(y, x) : B \& A} \&-I}{\text{snd } (y, x) : A} \&-E_1 \quad \frac{\frac{[y : B]^y \quad [x : A]^x}{(y, x) : B \& A} \&-I}{\text{fst } (y, x) : B} \&-E_0}{(\text{snd } (y, x), \text{fst } (y, x)) : A \& B} \&-I$$

↓

$$\frac{[x : A]^x \quad [y : B]^y}{(x, y) : A \& B} \&-I$$

## Part 4

# The Curry-Howard Isomorphism

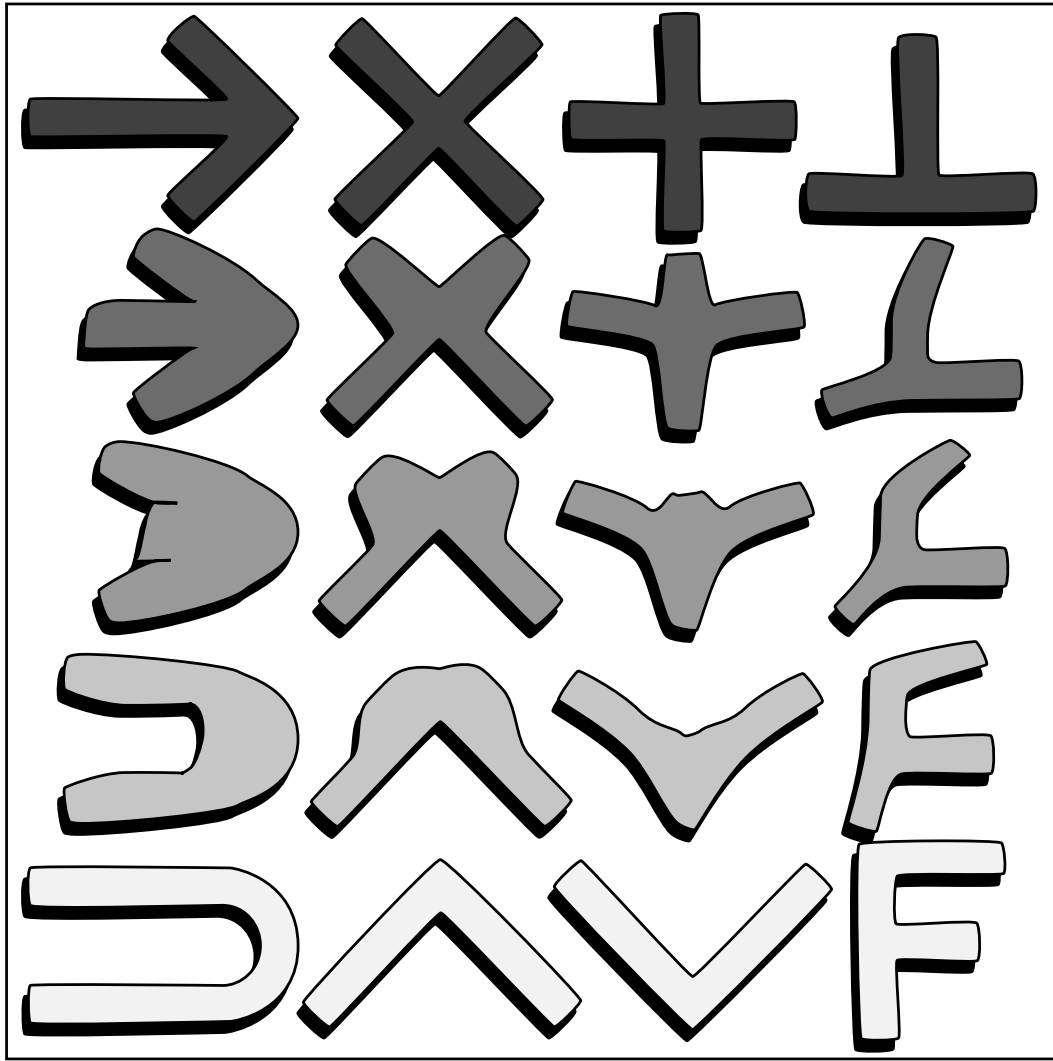

LC'90

*The Curry-Howard homeomorphism*

Haskell Curry (1900–1982) / William Howard



# Howard 1980

## THE FORMULAE-AS-TYPES NOTION OF CONSTRUCTION

W. A. Howard

*Department of Mathematics, University of  
Illinois at Chicago Circle, Chicago, Illinois 60680, U.S.A.*

*Dedicated to H. B. Curry on the occasion of his 80th birthday.*

The following consists of notes which were privately circulated in 1969. Since they have been referred to a few times in the literature, it seems worth while to publish them. They have been rearranged for easier reading, and some inessential corrections have been made.



# Howard 1980

## 1. Formulation of the sequent calculus

Let  $P(\supset)$  denote positive implicational propositional logic. The prime formulae of  $P(\supset)$  are propositional variables. If  $\alpha$  and  $\beta$  are formulae, so is  $\alpha \supset \beta$ . A *sequent* has the form  $\Gamma \rightarrow \beta$ , where  $\Gamma$  is a (possibly empty) finite sequence of formulae and  $\beta$  is a formula. The axioms and rules of inference of  $P(\supset)$  are as follows.

(1.1) Axioms: all sequents of the form  
 $\alpha \rightarrow \alpha$

(1.2) 
$$\frac{\Gamma, \alpha \rightarrow \beta}{\Gamma \rightarrow \alpha \supset \beta}$$

(1.3) 
$$\frac{\Gamma \rightarrow \alpha \quad \Delta \rightarrow \alpha \supset \beta}{\Gamma, \Delta \rightarrow \beta}$$

(1.4) Thinning, permutation and contraction rules

# Howard 1980

## 2. *Type symbols, terms and constructions*

By a type symbol is meant a formula of  $P(\supset)$ . We will consider a  $\lambda$ -formalism in which each term has a type symbol  $\alpha$  as a superscript (which we may not always write); the term is said to be of type  $\alpha$ . The rules of term formation are as follows.

(2.1) Variables  $X^\alpha, Y^\beta, \dots$  are terms

(2.2)  $\lambda$ -abstraction: from  $F^\beta$  get  
 $(\lambda X^\alpha . F^\beta)^\alpha \supset \beta$ .

(2.3) Application: from  $G^\alpha \supset \beta$  and  $H^\alpha$   
get  $(G^\alpha \supset \beta H^\alpha)^\beta$ .

Part 5

Aliens

# How to talk to aliens

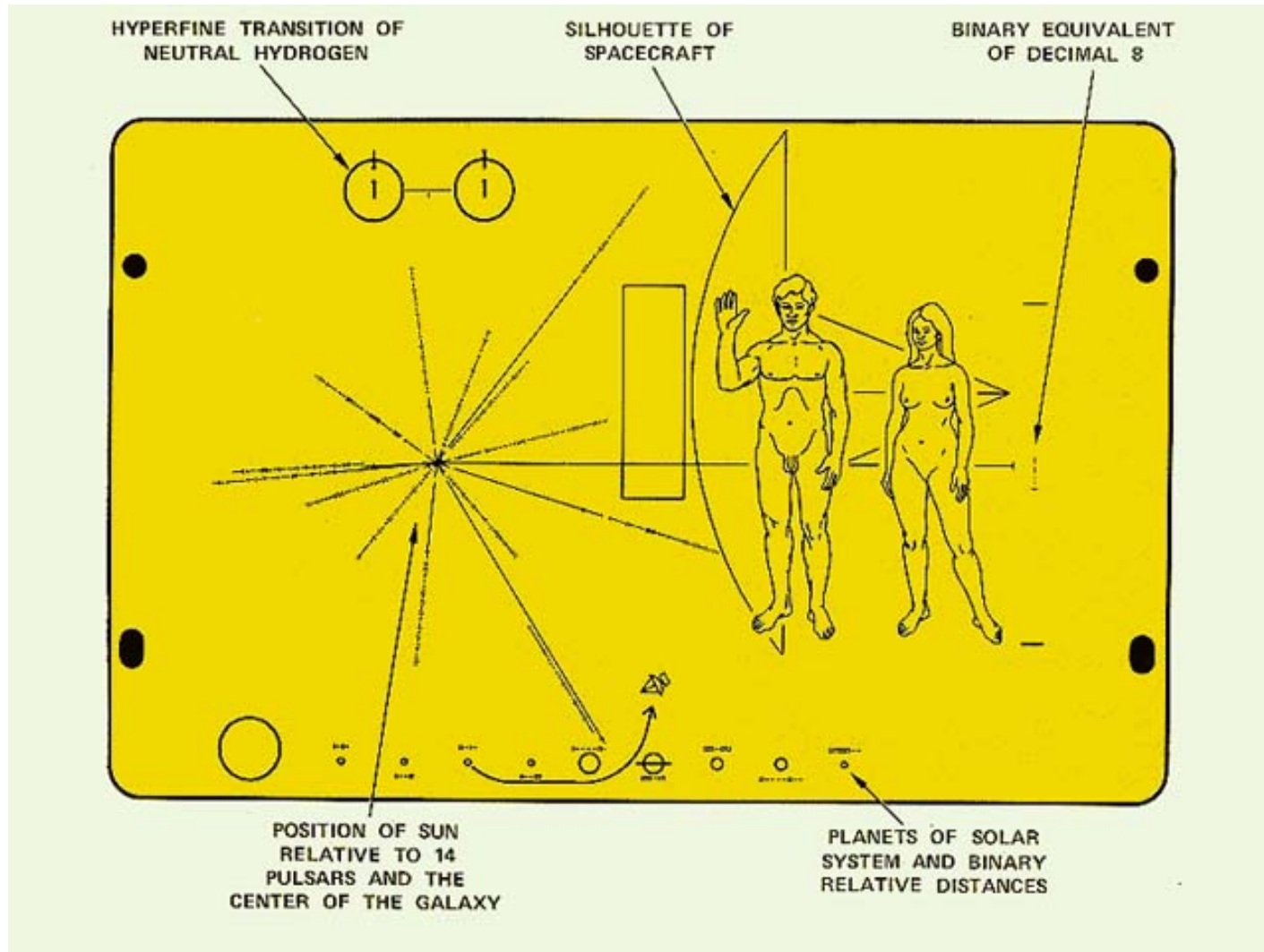

# Independence Day



# A universal programming language?

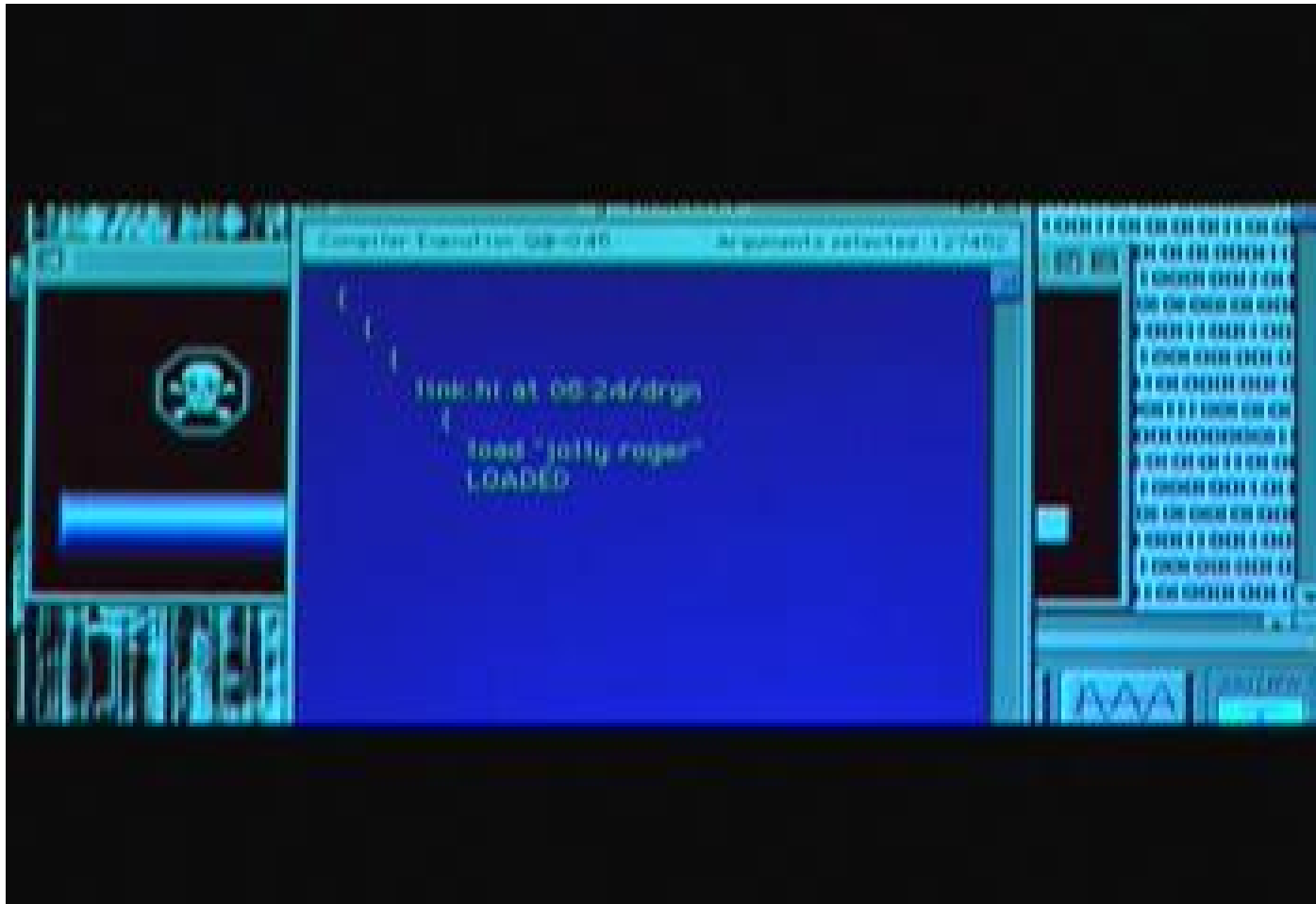

# Lambda is Omniversal

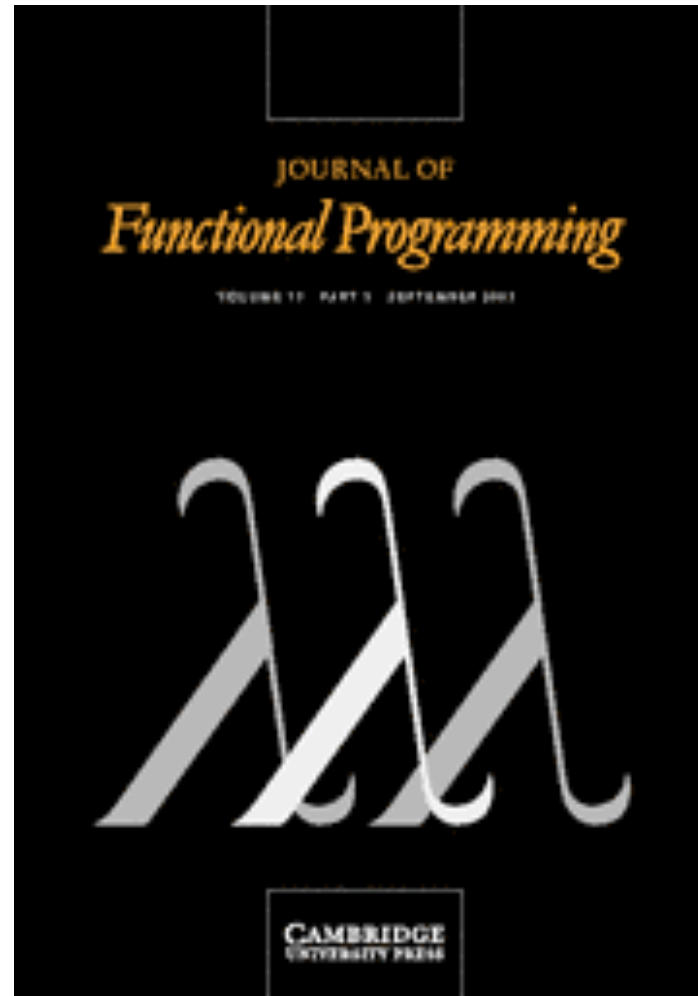

## Special thanks to

Willem Heijltjes, Tamise Totterdel, Alex Simpson  
for making the course run

Adam and Leora Wadler  
for inspiration

You  
for listening