

Informatics 1 - Computation and Logic: Tutorial 5 Solutions

Computation: Introduction to Finite State Machines

Week 7: 29 October - 2 November 2012

1. Consider the following finite state machine over the (input) alphabet $\{0, 1\}$:

There are just two states, called state A and state B. State A is the initial state. State A is the only accept state. There are transitions labelled '0' from state A to itself and from state B to itself. There are transitions labelled '1' from state A to state B and from state B to state A.

Draw this machine.

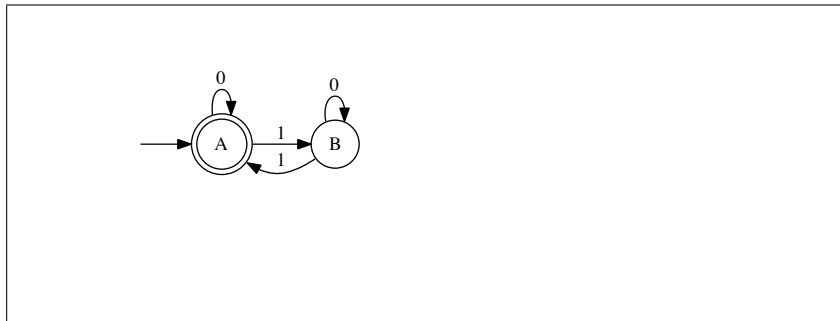

2. Which of the following strings are accepted by this machine? (Y/N)

ϵ	Y
0	Y
1	N
00	Y
01	N
10	N
11	Y
101	Y
010	N
0011	Y
1011	N
1010	Y
10001	Y
11011000101	Y

3. What property is shared by all the strings which are accepted by this machine?

They contain an even number of 1's.

4. Does the machine accept all strings with this property?

Yes.

5. What do the two states 'mean'?

State A means that the machine has seen an even number of 1's so far. State B means that it has seen an odd number of 1's so far.

6. Fill out the following table so that the entry in row x column y contains the names of all states that can be reached from state x by a transition labelled y in the above machine:

	0	1
state A	A	B
state B	B	A

Use the table to decide whether or not the machine is deterministic.

Yes, it is deterministic since every cell contains exactly one possible state transition.

7. Consider the following finite state machine over alphabet $\{0, 1\}$:

There are just three states — state A, state B and state C. State A is the initial state. State C is the only accept state. There are transitions labelled 0 from state A to state B, from state B to state C, and from state C to itself. There are transitions labelled 1 from state A to itself, from state B to state A, and from state C to itself.

Draw this machine.

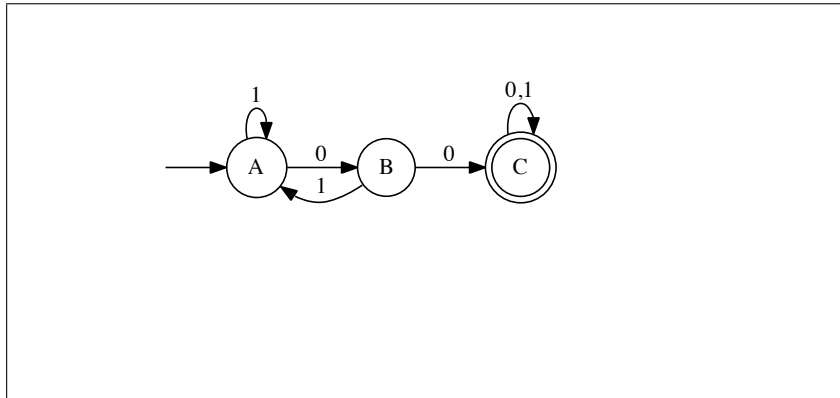

8. What language is defined by this machine? (Think about what the states ‘mean’.)

The set of all and only strings over $\{0, 1\}$ containing two successive 0’s. State A means that the machine hasn’t yet seen two successive 0’s and the last symbol was a 1. State B means that the machine hasn’t yet seen two successive 0’s and the last symbol was a 0. State C means that the machine has seen two successive 0’s.

9. Fill out its table:

	0	1
state A	B	A
state B	C	A
state C	C	C

Is the machine deterministic?

Yes, it is deterministic since every cell contains exactly one state.

10. Draw a finite state machine over alphabet $\{0, 1\}$ which accepts all and only those strings of which the string 101 is a substring.

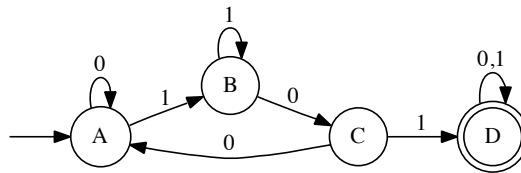

State A: I haven't yet seen 101, and the last thing I saw was 00 (if at least 2 symbols have been seen). State B: I haven't yet seen 101 and the last thing I saw was 1. State C: I haven't yet seen 101 and the last thing I saw was 10. State D: I've seen 101! Transitions labelled 0 from A to A, from B to C, from C to A, and from D to D. Transitions labelled 1 from A to B, from B to B, from C to D, and from D to D.

11. Draw a finite state machine over alphabet $\{0, 1\}$ which accepts all and only those strings consisting of a specified number of 0's followed by *exactly the same* number of 1's?

This is not possible because FSMs do not have a global counter.

This tutorial exercise sheet was written by Paolo Besana and revised by Thomas French. Send comments to s.bijani@ed.ac.uk